

## **Performance Analysis of Different Linearly Polarized Modes for Two Channel MDM Passive Optical Network**

Talwinder Singh

*Department of Electronics and Communication Engineering, Chandigarh University, Gharuan, Mohali - 140413, Punjab, India;*

### **Abstract**

**Background/Objectives:** The main aim of this research paper is to evaluate the different linearly polarized modes for two channel MDM passive optical network. **Methods/Statistical Analysis:** In this work mode division multiplexing from 48 users. Three different combinations of linear polarized modes is tested for odd modes, even modes and consecutive modes. System evaluated for 55 Km also on higher launched powers. **Findings:** Results revealed that mode number 1,3 and 5 perform better and suffered from less mode crosstalk. However even modes perform less effective than odd modes but better than mode number 1,2 and 3. Further 16 user for each mode is splitted and 10 dB optimal power is found, beyond this power system performance degraded. LP 01 provide maximum quality factor and worst in case of LP 21 mode.

**Keywords:** Mode Division Multiplexing (MDM), Passive Optical Network (PON), Time Division Multiplexing (TDM), Linear polarized (LP).

### **I. Introduction**

With the advancement in communication technology the need for high speed internet is increasing day by day which further demands high data rate and large bandwidth. So our future technology is required to be adaptable to offer large bandwidth and to support large number of new applications. To solve this problem fiber optic technology has been developed which uses optical light as a transmission medium. Optical fiber provides us adequate solution to solve the problem of access network [16]. Optical fiber technology offers us a combination of low error probability, high bandwidth and large transmission capacity [2]. GPON and Spatial mode multiplexing is a best choice to provide multispeed high data rate, high efficiency and full services of future time FTTH system and counts the ideas of facility providers at the identical instance [17]. MDM PON is observed at the same time as solitary of the premium technology to provide broadband access network in future.

Access networks are made out of copper and were based on twisted pair and coaxial cables. The three main requirements of access network are they must be cost efficient, they must have high reliability and better performance. Passive optical network (PON) requires only passive components i.e it doesn't require continuous supply of electricity, therefore power issues and heat are not considered. Passive optical network has low maintenance cost since it requires less components [1]. Fiber based networks are cheaper to operate. copper based networks requires lot of maintenance and repair as compared to optical network, which is less prone to outside conditions could lead to important operational savings for operation in long run [15]. Thus to provide broadband services to the end users several

FTTH and FTTP network has been proposed. FTTH is 100% deployment of optical fiber [14] As the signal travels through the fiber its power declines due to the presence of various non-linearities in the fiber [18].

Modes are light intensity profiles (patterns) that propagate down the fiber maintaining their transversal field shape. Multimode fibers can support many thousands of modes. Single mode fibers support one mode and few mode fiber can support some modes not all. In order to accurately study optical modes, the complete Maxwell equations are to be solved. For multimode fibers, the following intuitive explanation can be given: Each mode corresponds to a light beam traveling inside the fiber core with different angles.

Intensity of light propagate in more than one mode carrying fiber by sequence of the reflections at the boundary of the more dense medium and less dense medium that is core and cladding. Commencing a geometrical aim to see in the context of the ray and electromagnetic part, it is envisaged that the any angle is correct if we see ray concern however when later is discussed then it is seen that just definite angles are allowed, simply this refers as the fiber modes or modes in the context of fiber. By going in the matter with great concentration there are more than modes are exists that are the modes which travel near axis are referred as the meridional modes, as well as those that pass through in a helical fashion, identified as skew modes.

A luminosity wave is an electromagnetic wave that engagements from side to side the vacuum of external space. Luminosity waves are formed by vibrating electric charges. The electromagnetic wave is a transverse wave that has together an electric and a magnetic component. As an electromagnetic wave schedule the vibrations occurs

in extra level surface of shaking. A glow wave that is vibrating in additional than solitary level surface is referred to as un-polarized light. Light emitted through the sun, by means of a lantern in the classroom, or through a candle fire is un-polarized luminosity. Such brightness waves are shaped by electric charges that quiver in a diversity of orders, consequently creating an electromagnetic wave with the intention of vibrates in a variety of orders.

It is potential to change un-polarized luminosity into polarized beam. Polarized light waves are luminosity waves in which the ambience happen in a lone flat surface. The procedure of transforming un-polarized luminosity into polarized light is recognized as polarization. The directory incline causes rays which are traveling at steeper angles in the fiber, the high direct modes, to hold up by means of energy travelling at low angles. This is for the reason that that, even though the steeper rays have more to pass through the refractive index they practice close to the core/cladding edge is a smaller amount than at the canter of the core as well as so they tour quicker in this section. It is this characteristic of graded-index fiber with the purpose of give it a large amount less pulse dispersion than step-index fibers furthermore for this reason finer bandwidth show.

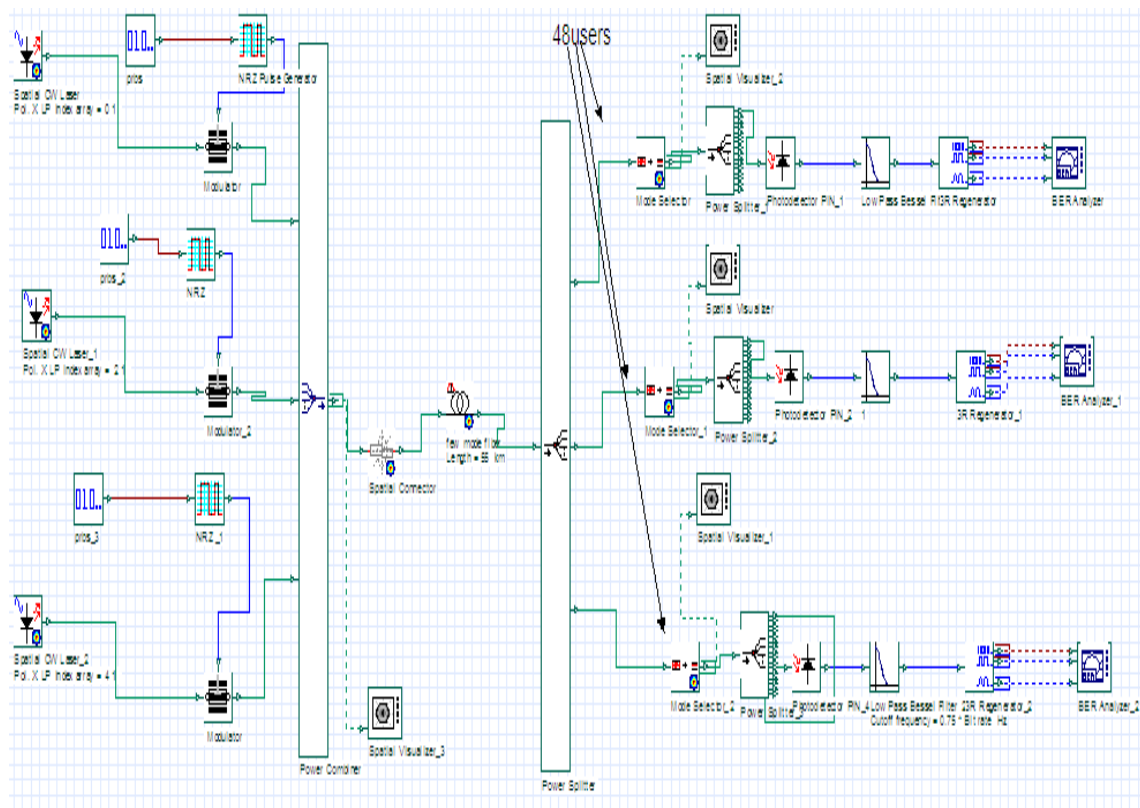
The context of the electromagnetic aim of vision, there are really four dissimilar types of manner in a multimode fiber depending on the angle among the electric field vector and the axis of the fiber.

The LP modes are usually selected by two parameters; these are the radial mode number,  $m$ , and the azimuthal mode number,  $n$ . For a particular mode  $n'$  corresponds to the number of intensity peaks in the radial direction and  $2m'$  corresponds to the number of intensity peaks over 360 degrees in the azimuthal direction. Mode number can be calculated as

$$M=n+2m-1 \quad \dots\dots 1$$

## II. System Setup

Proposed system consisting of three transmitter lasers at 1310nm and operated at three different intensity profiles such as mode number 1, 3 and 7. Generally taken as LP 01, LP 21 and LP 41 mode profiles and calculated there mode number from above stated equation. PRBS is used to generate the random data bits at 20gbps followed by non- return to zero line coding. Signal is in electrical domain after NRZ and thus to convert in optical given to intensity modulator called mechzander modulator. Output data from three transmitter using different modes is combined with power combiner. After power combiner a spatial connector is placed, which is here incorporated to couple modes to few mode fiber. A spatial visualizer is used to show different modes after combiner. A few mode fiber is choose Lp transmit modes because it is suffered from less mode crosstalk due less mode supportability. Length of fiber is 55 Km having 0.2 dB/Km losses. System setup diagram is shown in fig 1

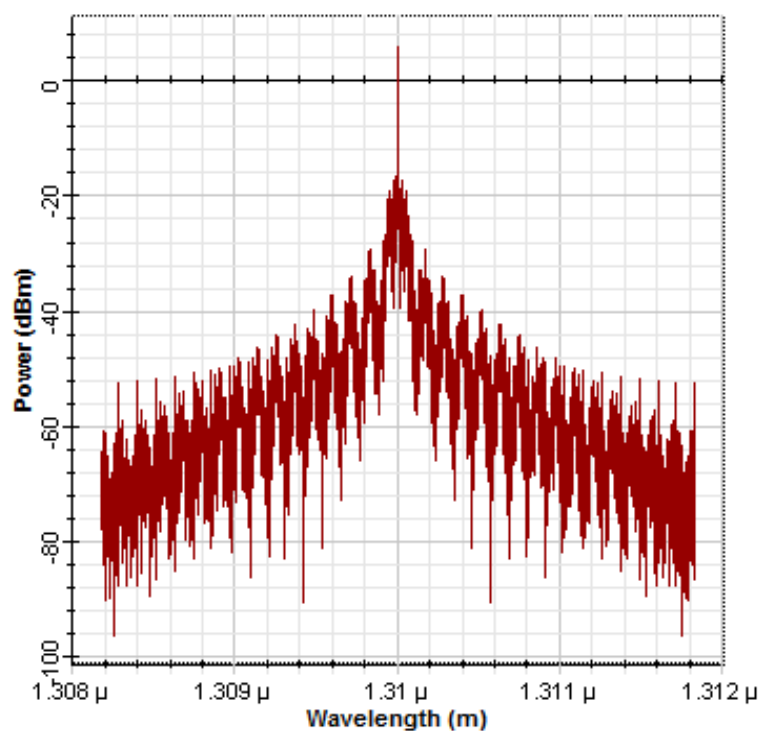


**Fig 1 System setup for mode multiplexed PON**

A power demultiplexer is then followed by few mode fiber and mode selector. Mode selector is for selecting the different modes from mixed data signals. Now as signal is filtered out and splitted to 16 user for each mode so as to give signals to multiple users. Passive splitter is said because it does not use any power. Each splitted signal is extracted by photo detector to convert optical signal into electrical signal. A low pass Bessel filter then fiber out noises from electrical signals and further signal fed to 3-R regenerator for re amplify re shape and re sample signal. A BER finally represents the Q-factor and bit error rate for final evaluation.

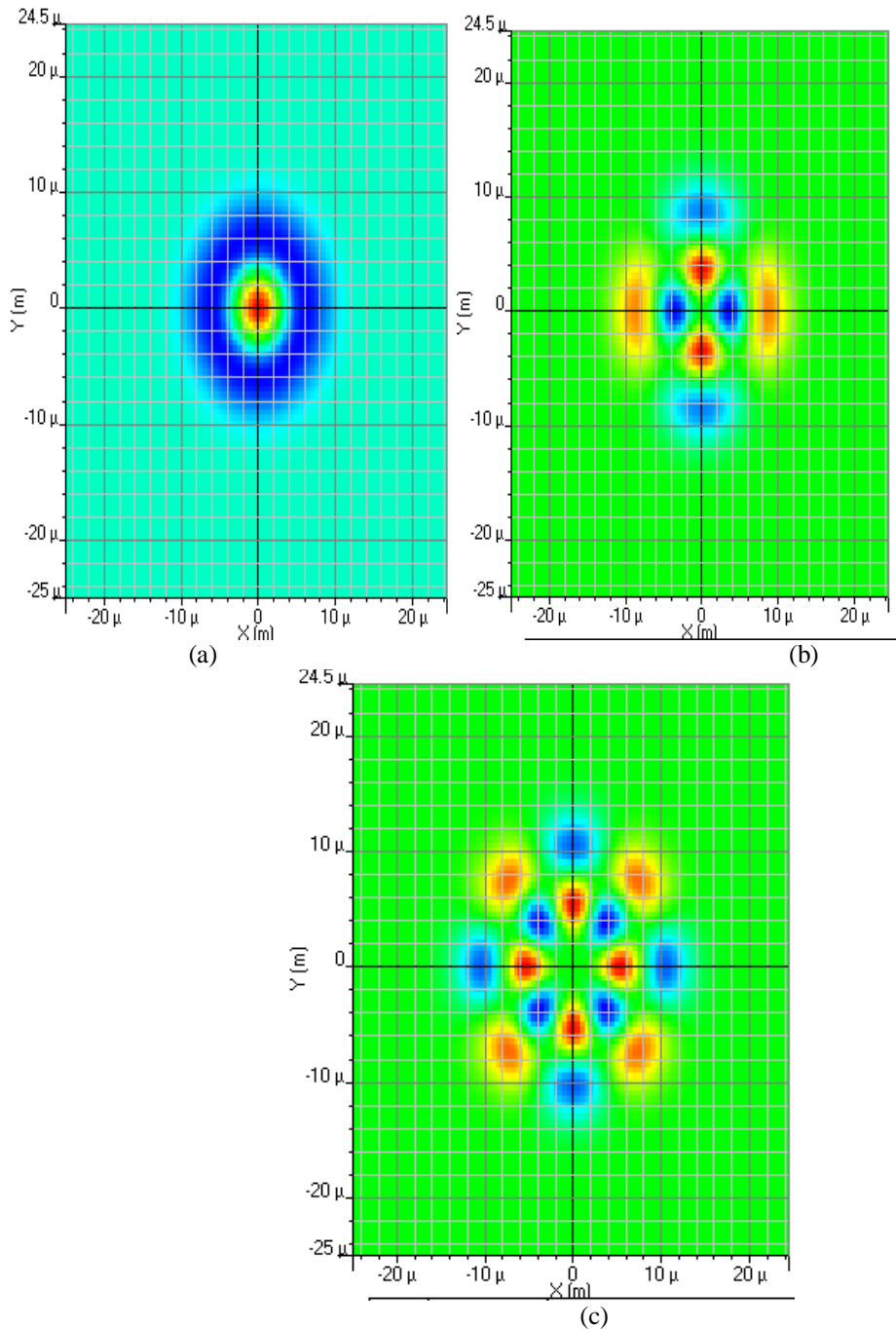
### III. Results

In this section observations are carried out at different points from visualizers. This system operates for three cases such as consecutive modes, odd modes and even modes. It is clearly reported that in case of consecutive linearly polarized modes, output signal is very noisy and support very less users due to maximum crosstalk. In second case where even modes transmitted, noise is little less then former case and improved results are observed. Lastly even modes are analyzed and supports maximum users 48 and 16 users splitted for each mode. Maximum Q-factor and less BER is reported in this case. Optical spectrum after transmitter is shown in fig2



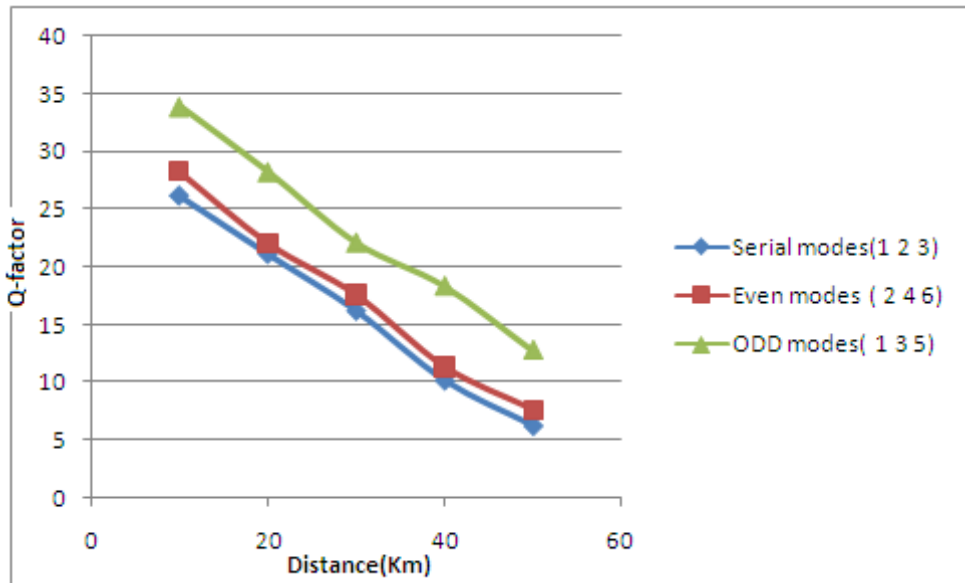
**Fig 2 Optical spectrum after power combiner**

Three different linearly polarized mode profiles are shown in fig3

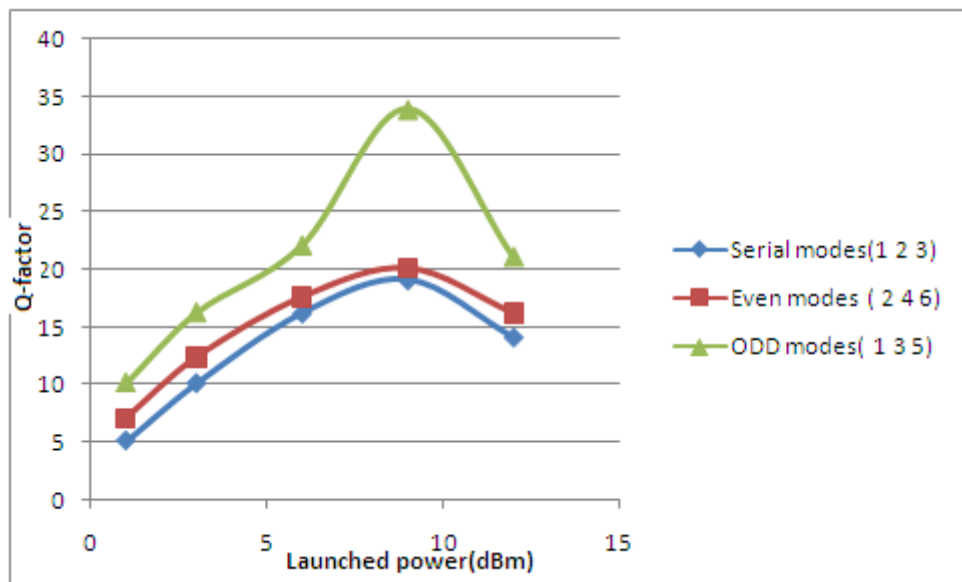


**Fig 3 Linearly mode profiles for (a) Mode 1 (b) Mode 3 (c) Mode 5**

Comparative analysis over different distance has been done 10Km 20Km 30Km 40KM and 50 Km for three different modes. Also tested for input power for all types modes and observed that at high power mode crosstalk increases.

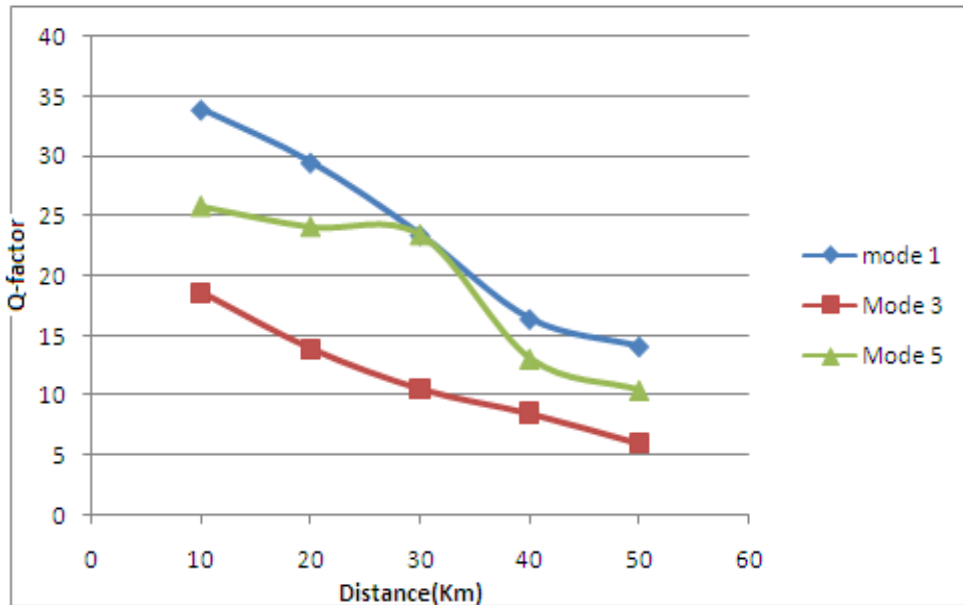


**Fig 4 Q-factor versus Distance for different order modes at distances**



**Fig 5 Q-factor versus Launched power**

Maximum power is found to be 10 dB beyond this power nonlinear effects appears. Now we concluded that odd modes are best in performance and further 1 3 and 5 modes are compared to each other along with eye diagrams. Mode first provide best results among 3<sup>rd</sup> mode and 5<sup>th</sup> mode.



**Fig 6 Graphical representation of 0mode 1,2 and 3 vs distance**

#### IV. Conclusion

In this work, work has been done for mode division multiplexing from 48 users. Three different combinations of linear polarized modes is tested for odd modes, even modes and consecutive modes. System evaluated for 55 Km also on higher launched powers. Results revealed that mode number 1,3 and 5 perform better and suffered from less mode crosstalk. However even modes perform less effective than odd modes but better than mode number 1,2 and 3. Further 16 user for each mode is splitted and 10 dB optimal power is found, beyond this power system performance degraded. LP 01 provide maximum quality factor and worst in case of LP 21 mode.

#### Reference

- [1] Sumedha Kaushik, AnkurSinghal, "Mitigation of crosstalk in Passive optical Network," International Journal of Advanced Research in Computer Science and Software Engineering, vol. 2, issue 5, pp.317-320, May 2012.
- [2] Raman, Simranjeet Singh, "Investigation of hybrid WDM/TDM PON in presence of optical amplifiers to enhance the system capacity", International Journal of Advanced Research in Computer Science and Software Engineering, vol.3, issue 9, pp.90-96, September 2013.
- [3] SahanaBano, R.S Yadav, "A novel architecture for hybrid WDM/TDM passive optical network with using FEC encoding", International journal of innovative research and studies, vol.2, no.10, October 2013.
- [4] Garima Arora, Sanjeev Dewra, "DWDM transmission using hybrid optical amplifier", International Journal of Advanced Research in Computer and Communication Engineering, vol.3, no.4, pp.6174-6177, April 2014.
- [5] Sandeep Singh, Arvind Kumar Jaiswal, MukeshKumar, "Transmission of Voice, Video and Data in Fiber-To-TheHome (FTTH) Networks Using OFDM", International Journal of Advanced Research in Computer Science and Software Engineering, vol.2, no.5, pp.41-45, May 2012.
- [6] Ramandeepkaur ,Rajneesh Randhawa, R.S Kaler, "Performance evaluation of optical amplifier for 16x10, 32x10, 64x10 Gbps WDM system", Optik-International Journal for Light and Electron Optics, vol.124, issue 8, pp.693-700, April 2013.
- [7] Komalpreet Kaur, Rajneesh Randhawa, R.S.Kaler, " Low cost architecture to integrate multiple PON's to long reach spectrum sliced WDM networks", Optik-International Journal for Light and Electron Optics, vol.125, issue 16, pp.4513-4516, August 2014.
- [8] Komalpreet Kaur, Rajneesh Randhawa, R.S.Kaler, "Performance analysis of WDM-PON architecture using different receiver filters", Optik-International Journal for Light and Electron Optics, vol. 125, no.17, pp.4742-4744, September 2014.
- [9] MdShamim Ahsan, Man Seop Lee, S.H Shah Newaz, Syed Md.Asif, "Migration to the Next Generation Optical Access Networks Using Hybrid WDM/TDM-PON ", Journal of Network, vol.6, no.1, pp.18-25, January 2011.
- [10] Veronica Fernandez, Robert J. Collins, Karen J. Gordon, Paul D. Townsend, Gerald S. Buller, "Passive Optical Network Approach to GigaHertz-Clocked Multiuser Quantum Key Distribution", IEEE Journal of Quantum Electronics, vol. 43, issue 2, pp.130-138, February 2007.



- [11] A.Emsia, Q. T. Le, M. Malekizandi, D. Briggmann, I. B. Djordjevic, F. Kuppens, "WDM-TDM NG-PON Power Budget Extension by Utilizing SOA in the Remote Node", *IEEE Photonics Journal*, vol. 6, no.2, April 2014 Björn Skubic, Jiajia Chen, Jawwad Ahmed, Lena Wosinska, Biswanath Mukherjee, "A Comparison of Dynamic Bandwidth Allocation for EPON, GPON, and Next-Generation TDM PON", *IEEE Comm.Mag.*, vol.7, no.3, pp.40-48, March 2009.
- [12] Nimrat Kaur, Malti Sarangal, "Effects of using RZ and NRZ modulation formats for TDM PON system on Transmission Characteristics for Downstream Signals", *International Journal Of Computer Applications Technology And Research*, vol. 2, issue 6, pp.645 - 649, December 2013.
- [13] M.Baskar, T.Gnanasekaran, T.S.Arulananth, "Passive Optical Network Supporting Seamless Integration of RoF and OFDMA Signals", *International Journal of Engineering Research*, vol.3, issue 12, pp.726-729, December 2014.
- [14] Jisha V S, Sunaina N, "Performance Analysis of Hybrid WDM/TDM PON Using Various Coding Techniques," *International Journal of Science and Research*, vol.4, issue 1, pp.485-488, January 2015.
- [15] Yuanqui Luo, Jian Jun Yu, Juiqiang Hu, Lei Xu, Ji P.N., Ting Wang, Cvijetic M., "WDM-PON with parallel detection for video and data delivery", *IEEE Optical Fiber comm. and National Fiber Optic Engineers Conf.*, pp.1-3, March 2007.
- [16] R. Randhawa, S.Singh, J.S Sohal, R.S kaler, "wavelength converter using semiconductor optical amplifier Mach-zender interferometer based on XPM at 40 Gb/s for future transport network", *Fiber and Integrated Optics*, vol.28, issue 2, pp.154-169, March 2009.
- [17] K.E Rookstool, "Economic consideration of central office broadband distribution terminal versus remote terminal (RT) broadband distribution terminals for deploying fiber to the home (FTTH)", *Optical Fiber Comm. Conf.*, vol.2, pp.610-611, March 2003.
- [18] S.Singh, R.S Kaler, "Transmission performance of 20 X 10 Gb/s WDM signals using cascaded SOA with OOK and DPSK modulation formats", *Optical comm.*, vol.1, pp.100-110, 2006.
- [19] N.Kikuchi, S.Sasaki, "Analytical evaluation technique of self phase modulation effect on performance of cascaded optical amplifier system", *IEEE Journal of Lightwave Technology*, vol.13, no.5, pp.868-878, May 1995.
- [20] M.L Nielsen, K.Tsuruoka, T.Kato, T.Morimoto, S.Sudo, T.Okamoto, K.Mizutani, H.Sakuma, K.Sato, Kuji Kudo, "SOA booster integrated mach-zehnder modulator: investigation of SOA position," *IEEE journal of Lightwave Technology*, vol.25, issue 5, pp.837-846, March 2010.
- [21] Amitabha Banerjee, Youngil Park, Fredrick Clarke, Huan Song, Sunhee Yang, Glen Karter Kwangjoon Kim, Biswanath Mukherjee, "wavelength division multiplex (WDM) Passive optical technologies for broadband access", *Journal of Optical Networking*, vol.4, issue 11, October 2005.
- [22] C.H.Lee, S-M.Lee, K.-M. Choi, J.-H. Moon, S.-G. Kun, K-J. Jeong, J.H Kim, B.Kim, "Wavelength division multiplex (WDM) passive optical networks experience in Korea", *Journal of Optical Networking*, vol.6, issue 5, pp.451-464, October 2007.
- [23] Soo-Jin Park, Chang-Hee Lee, "Fiber to the home services based on wavelength division multiplexing passive optical network", *Journal of Lightwave Technology*, vol.22, no.11, pp.2582-2591, November 2004.
- [24] S.F Shaukat, V.Ibrahim, Saba Nazir, "Monte Carlo analysis of broadband passive optical network", *International Digital Organization for Scientific Information*, vol.12, no.5, pp.1156-1164, 2011.